

# Seatext®

## Product Datasheet



# WFS

ENERGY & ENVIRONMENT

## THROUGH-WATER AND THROUGH-GROUND RADIO MODEM

Seatext® is the world's first commercial through water and through-ground radio communication system, designed to interface with sensors and control units.

Seatext® can be readily tailored to numerous applications: e.g. environmental monitoring of rivers, lakes estuaries and landfill sites, oceanographic monitoring, process control and communications in underground mines, culverts, and water/wastewater networks.



### KEY FEATURES & BENEFITS

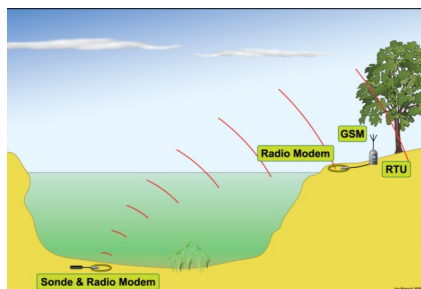

#### CROSSES WATER / AIR INTERFACE

Allows unobtrusive and seamless transmission through water and through ground, removing the need for cables or repeater buoys. In addition the Seatext® does not need line of sight to transmit, is covert and poses no hazard to navigation.

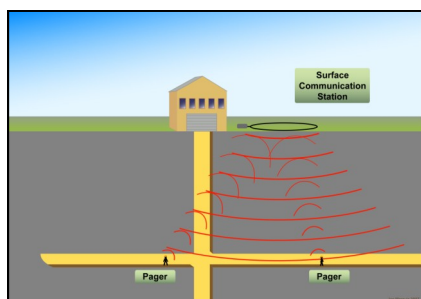

#### PENETRATES THE GROUND AND ICE

Effectively allows for two way transmission of data through rock and soil. Removes the need for vulnerable cabling while allowing for greater freedom to staff underground. Could be exploited in underground tunnels used by transport links such as metro systems to support communications infrastructures.



#### CLEAN, INTERFERENCE-FREE TRANSMISSION

Seatext® operates without interfering with acoustic sensors or sonars and can be used without the ill effects to aquatic life often attributed to acoustic technology.



#### EFFECTIVE IN COMPLEX ENVIRONMENTS

Unlike acoustic systems, WFS's radio Technology is unaffected by acoustic noise, turbidity, mud or ice and will operate in shallow water as well as congested environments such as harbours, estuaries and waterways.

Through-water & through-ground radio modem: Seatext® v3.3

# THROUGH-WATER AND THROUGH-GROUND RADIO MODEM

## THE SYSTEM IS OPTIMISED FOR ENVIRONMENTAL APPLICATIONS SUCH AS:

- Water quality monitoring in rivers, reservoirs, lochs and the sea
- Rapidly deployable systems to investigate and monitor pollution incidents
- Control and telemetry in the water and waste water industries
- Measuring gas levels, gas pressure and the release of leachate at landfill sites
- Inspection and monitoring of marine renewable energy installations
- Monitoring underground pipe networks without disruption
- Sustainable practices in shallow-water dredging activity
- Real-time flood warning and flood monitoring
- Port and harbour operations

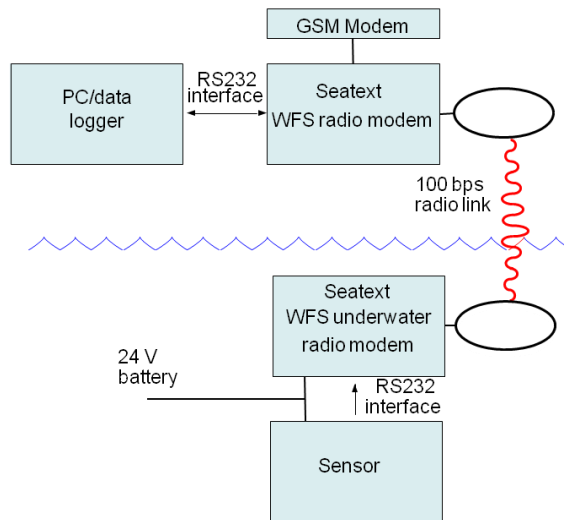
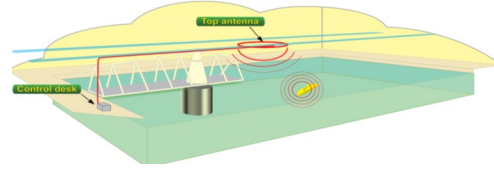

Diagram of Seatext® modem, set up to transmit from water to shore. The modem can be easily integrated with third party systems, in this example connecting to a laptop, GSM modem and Sensor.

## ADDITIONAL FEATURES

- Transceiver
- Immunity to thermal layers
- Fast propagation
- Can be connected in a network
- GSM option

## BENEFITS

- Two way communications
- Can be interfaced to text entry terminal for comms link
- High tolerance of water conditions
- Reduction in Doppler shift
- Extended coverage
- Global access

## TECHNICAL SPECIFICATIONS

### Performance

- Data rate = 100 bits/sec half duplex
- Multiplexing – multiple units uniquely addressable
- Modems can be connected in a network

### Antenna

- Loop
- Options available for extended range

### Data

- RS 232 data interface

### Hardware

- Can be customised to suit application

### Power Requirements

- 18-28V external power or battery pack to specific application
- 4W receiving / 16W transmitting / 5mW Sleep

### Environmental

- Depth tested to 50m  
- 3000m available on request
- Temp. operating -10 to + 35°C

FOR FURTHER INFORMATION PLEASE CONTACT

## WFS Energy & Environment

Unit 7 Houstoun Interchange Business Park  
Livingston, EH54 5BZ , UK

Tel: 0845 862 6600 | Fax: 0845 862 6601

